

<b>Project:</b>	
<b>Type:</b>	
<b>Catalog #:</b>	

### STANDARD

### OPTIONAL



### ILLUMINATION

- Two fully adjustable, 5W, MR-16 halogen lamp heads standard.
- Optional 3.3W white LED lamp heads.

### ELECTRICAL

- Dual 120/277 voltage.
- Charge rate/power "ON" LED indicator light and push-to-test switch for mandated code compliance testing.
- LVD (low voltage disconnect) prevents battery from deep discharge.
- 6V maintenance-free, rechargeable sealed lead acid battery.
- Internal solid-state transfer switch automatically connects the internal battery to lamp heads for minimum 90-minute emergency illumination.
- Fully automatic solid-state, two rate charger initiates battery charging to recharge a discharged battery in 24 hours.

### MOUNTING

- Surface mount via easy connect back plate, which fits most standard junction boxes and snaps into place making internal electrical connections.
- Knockout for conduit applications.
- Suitable for wall mount.

### HOUSING

- Injection-molded, engineering grade, 5VA flame retardant, high-impact resistant, thermoplastic in white or black finish.

### OPTIONS

- **SDT:** Self-diagnostic feature performs monthly, biannual, and annual tests to ensure reliable operation and meet electrical and life safety codes.
- **HTR:** Optional internal heater for cold temperature applications.
- **USA:** Substantial transformation assembly in the U.S. complies with "Assembled in the USA" under the Buy American Act.
- **LED:** 3.3W high performance MR-16 base LED lamps.

### WARRANTY / LISTING

- Five year warranty on all electronics and housing. Battery pro rated for two years.
- Meets UL924, NFPA 101 Life Safety Code, NEC, OSHA, Local and State Codes.
- UL Listed for damp locations (20°C – 40°C).

### DIMENSIONS

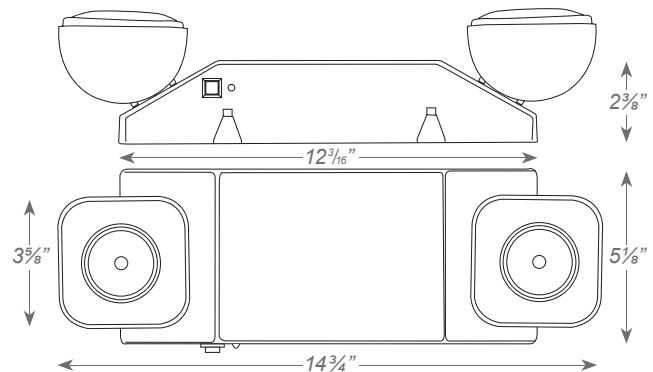

### ORDERING INFORMATION

Sample Part Number: **ECO-R-16**

MODEL	HOUSING COLOR		OPTIONS	
ECO-R-16	Blank	White	SDT	Self-Diagnostics
	B	Black	HTR	Internal Heater
			USA	Assembled in USA
			LED <sup>1</sup>	3.3W High Lumen White LED Lamp

Special voltage options available. Check with your Best Lighting representative.

<sup>1</sup> Not available with SDT option.

<b>Project:</b>	
<b>Type:</b>	
<b>Catalog #:</b>	

### ELECTRICAL INFORMATION

CATALOG NUMBER	INPUT WATTS (W)		INPUT AMPS (A)	
	120V	277V	120V	277V
ECO-R-16	3.5	4.9	0.031	0.019
ECO-R-16-SDT	4.5	4.5	0.040	0.030